

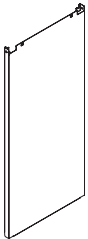

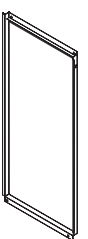

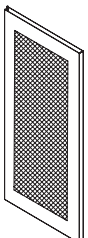
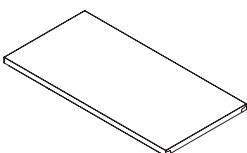
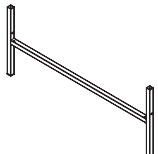
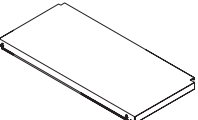
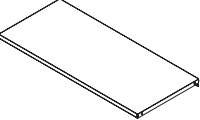
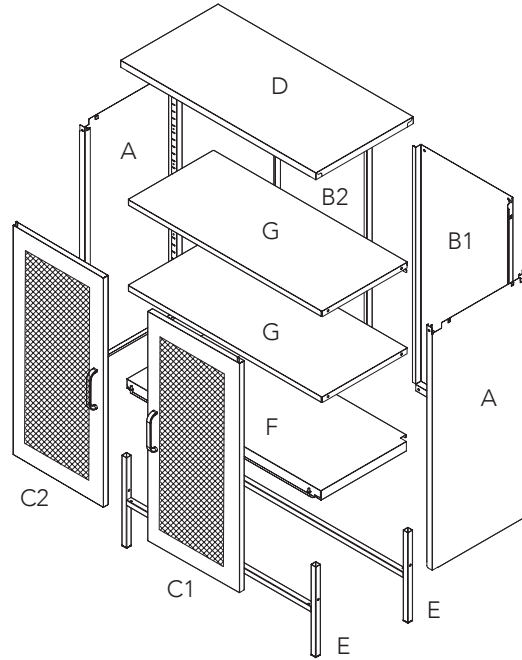
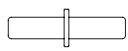

## Storage Locker Parts & Hardware

A 	B 
x2 Side Panels	x2 Back Panels
C 	D 
x2 Doors	x1 Top Panel
E 	
x2 Legs	
F 	G 
x1 Bottom Panel	x2 Shelves



H 	I 	J 
6 X 30mm	12 X 0.8mm	4 X 4mm
x2	x2	x4
K 	L 	M 
9 X 0.8mm		
x4	x2	x8

# Garden Trading®

## Marlborough Cabinet Assembly Instructions

Please read through these instructions and ensure they are kept for future reference.

All parts and hardware are listed on the back of this guide.

Please ensure the unit is securely fixed to the wall to avoid tipping. Fixings are not supplied. Please ensure you source and use correct plugs and screws for the surface you are fixing this product to.

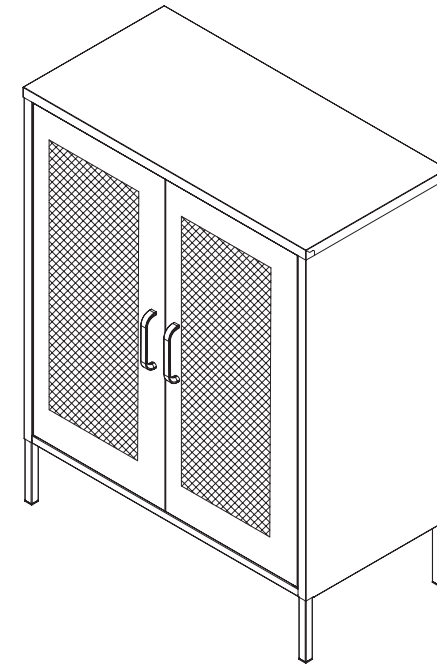

### Cabinet Care Instructions

Dust regularly with a clean dry cloth.

Wipe up any spills immediately with a damp cloth and then dry the surface with a clean dry cloth.

Never use abrasive or corrosive cleaning agents.

Always use place mats and coasters to protect the surface from moisture and heat. Avoid sharp objects scratching the surface.

Avoid placing on uneven surfaces.

Do not drag furniture, always lift to move.

Maximum Weight Capacity

Top Panel: 30kg

Shelf: 25kg (each)

Bottom Panel: 25kg

Customer Services:

[gardentrading.co.uk](http://gardentrading.co.uk)

+44 (0)1993 845 559

[customerservices@gardentrading.co.uk](mailto:customerservices@gardentrading.co.uk)

Opening Hours: Monday - Friday: 8.30am - 5.30pm (Friday close at 5.00pm)

The Garden Trading Company Ltd, Carterton South Industrial Estate, Black Bourton Road, Carterton, Oxon, OX18 3EZ

# Garden Trading®

1. Stand both legs (E) up and push the side panels (A) down onto the legs.

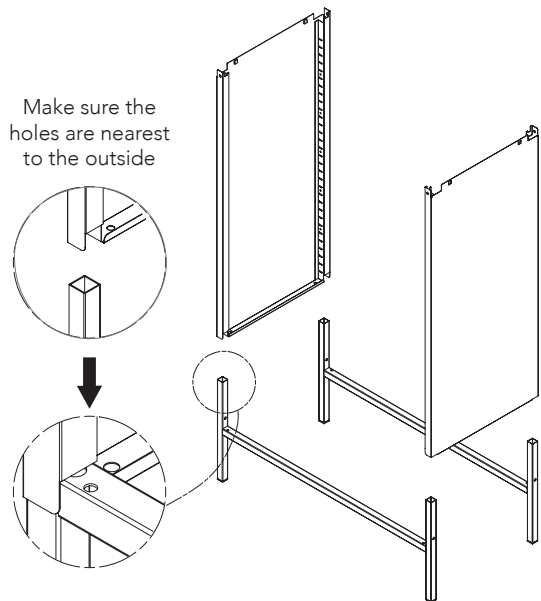

2. Assemble the back panels (B) by slotting them together.

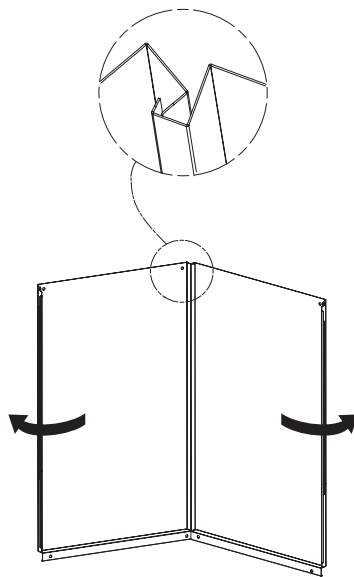

5. Add the top panel (D), starting from the front. Align the top with all the side and back panels and push down with enough force to click it into place. Check from all angles that the side and back panels have slotted in correctly.

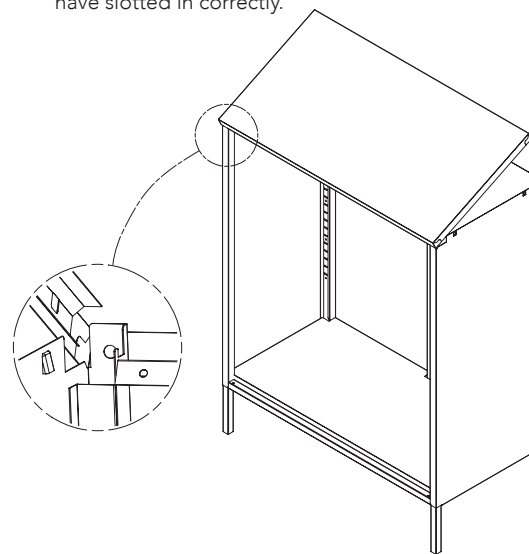

6. Insert the shelf brackets (M) and the shelves (G).

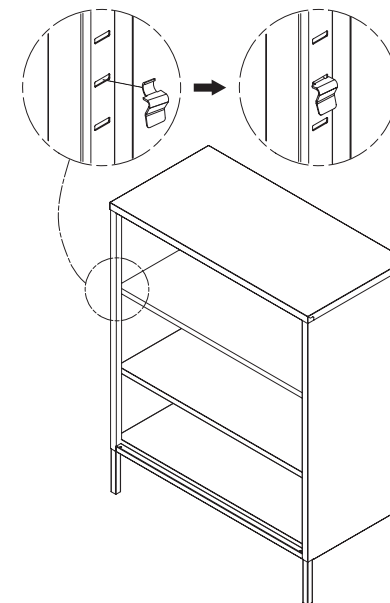

3. Assemble the back panels (B) onto the standing structure and bend the tabs in the four corners, to fix in place

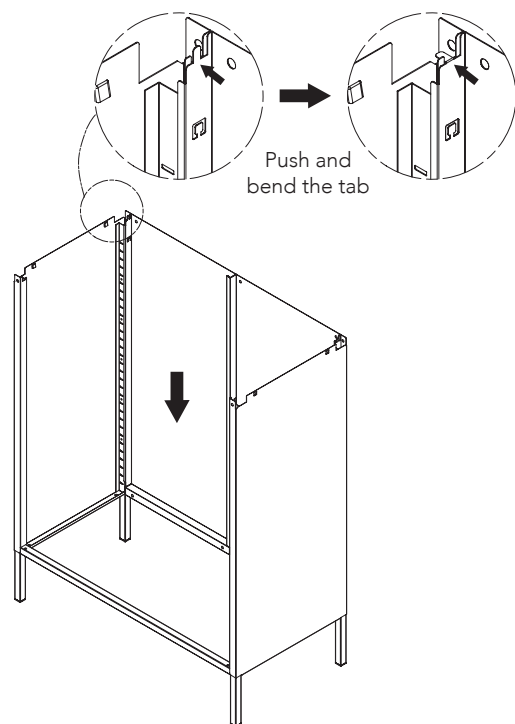

4. Insert the bottom panel (F), starting from the front and pushing it all the way down into place

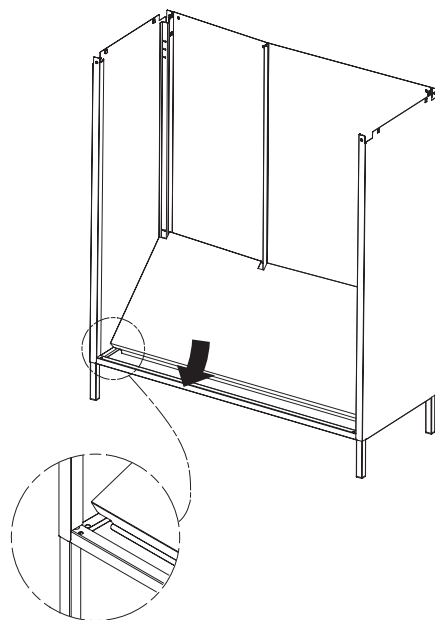

7. Insert the metal post (H) and washer (I) in the hole in the leg. Hinge the door (C) onto the post. Push down and hold the metal hinge button at the top of the door. Slide the door in place, releasing the hinge to fix into position within the top panel. Repeat for second door.

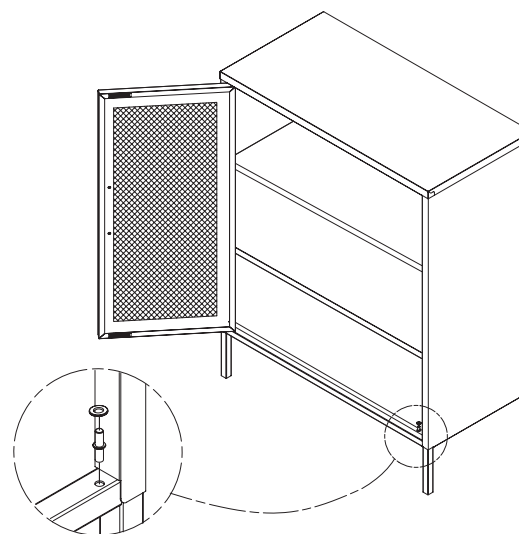

8. Using a screwdriver attach the handles (L) with the small screws (J) and small washers (K).

