

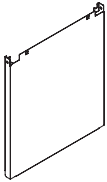

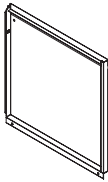

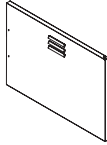

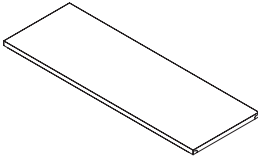
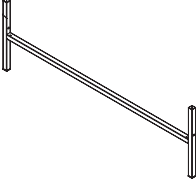
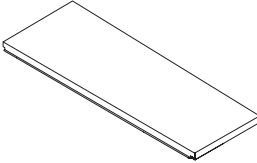
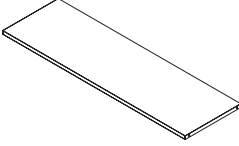

## Storage Locker Parts & Hardware

A	B	C	D
			
x2 Side Panels	x2 Back Panels	x2 Doors	x1 Top Panel

E	F	G
		
x2 Legs	x1 Bottom Panel	x1 Shelves

①	②	③
		
6 X 70mm	6 X 30mm	12 X 0.8mm
x2	x2	x2

④	⑤	⑥	⑦
			
4 X 4mm	9 X 0.8mm		30 X 13mm
x4	x4	x2	x4

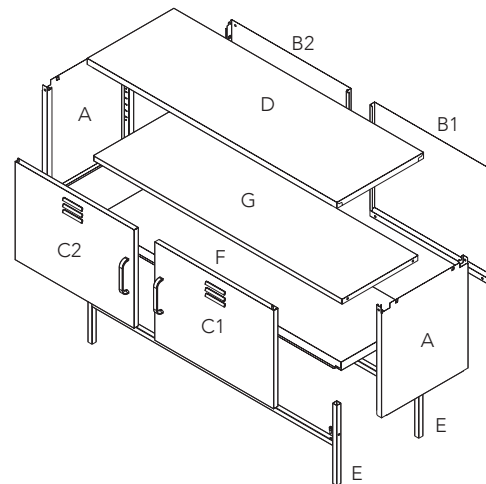

# Garden Trading®

## Marlborough Storage Locker Assembly Instructions

Please read through these instructions and ensure they are kept for future reference. All parts and hardware are listed on the back of this guide.

Please ensure the unit is securely fixed to the wall to avoid tipping. Fixings are not supplied. Please ensure you source and use correct plugs and screws for the surface you are fixing this product to.

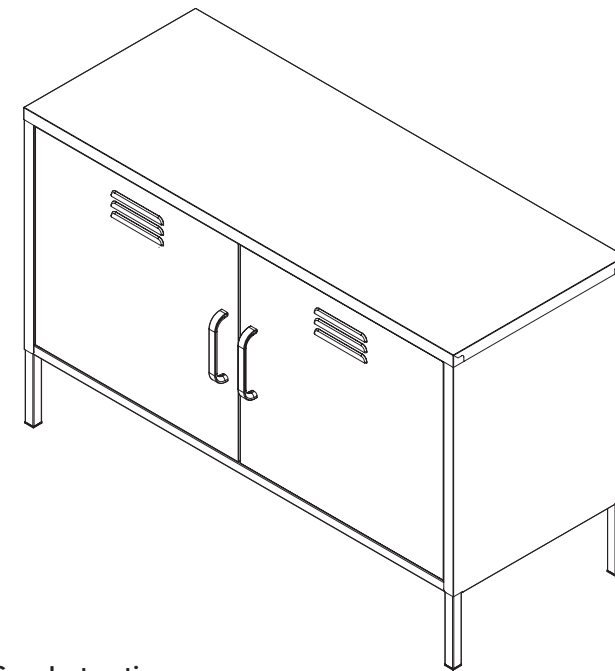

### Storage Locker Care Instructions

Dust regularly with a clean dry cloth.

Wipe up any spills immediately with a damp cloth and then dry the surface with a clean dry cloth.

Never use abrasive or corrosive cleaning agents.

Always use place mats and coasters to protect the surface from moisture and heat. Avoid sharp objects scratching the surface.

Avoid placing on uneven surfaces.

Do not drag furniture, always lift to move.

Maximum weight capacity

Top Panel: 30kg

Shelf: 10kg

Bottom Panel: 15kg

### Customer Services:

[gardentrading.co.uk](http://gardentrading.co.uk)

+44 (0)1993 845 559

[customerservices@gardentrading.co.uk](mailto:customerservices@gardentrading.co.uk)

Opening Hours: Monday - Friday: 8.30am - 5.30pm (Friday close at 5.00pm)

The Garden Trading Company Ltd, Carterton South Industrial Estate, Black Bourton Road, Carterton, Oxon, OX18 3EZ

# Garden Trading®

1. Stand both legs (E) up and push the side panels (A) down onto the legs.

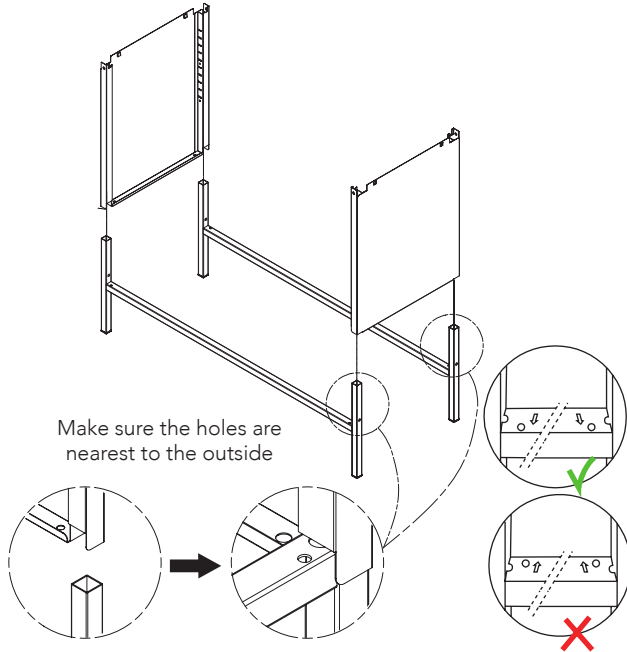

Make sure the holes are nearest to the outside

2. Assemble the back panels (B) by slotting them together.

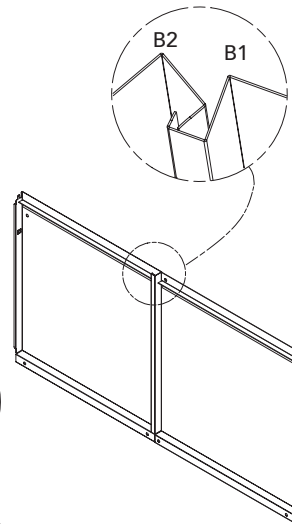

3. Assemble the back panels (B) onto the standing structure and bend the tabs in the four corners, to fix in place.

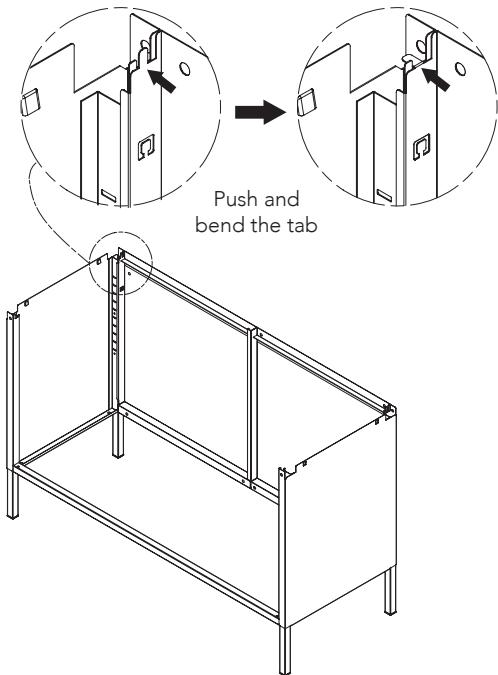

Push and bend the tab

4. Insert the bottom panel (F), starting from the front and pushing it all the way down into place.

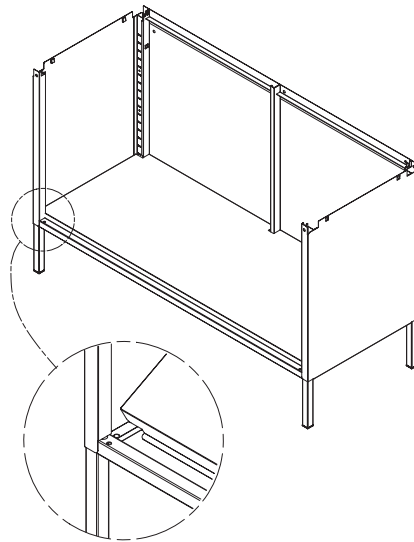

5. Add the top panel (D), starting from the front. Align the top with all the side and back panels and push down with enough force to click it into place. Check from all angles that the side and back panels have slotted in correctly.

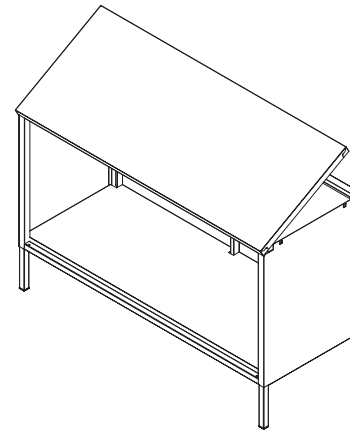

6. Insert the shelf brackets (7) and the shelf (G).

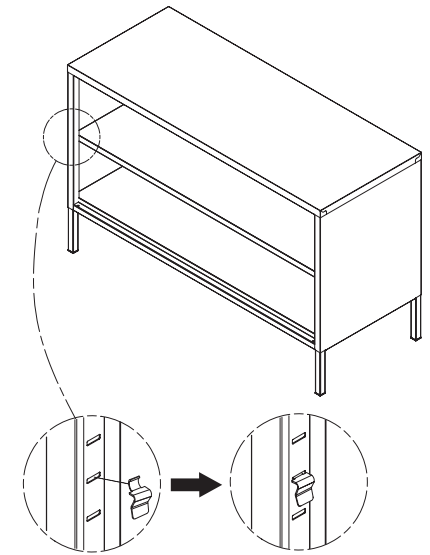

7. Insert the metal post (2) and washer (3) in the hole in the leg.

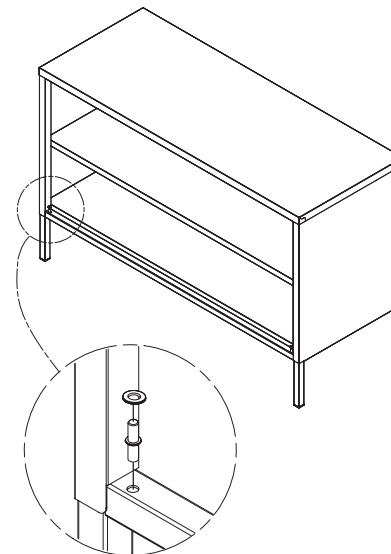

8. Slide the door down on the post and into correct position against the cabinet. At the top of the door, insert L-shape (1) post up into position through the holes and bend the tab to secure in place.

Using a screwdriver attach the handles (6) with the small screws (4) and small washers (5).

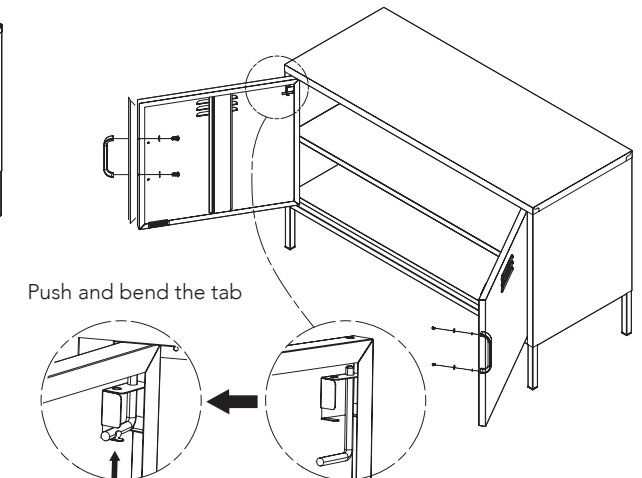

Push and bend the tab