

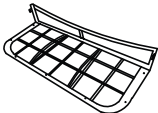



Parts & Hardware

A		x 1 PC
B		x 1 PC
C		x 1 PC
D		x 9 PC
E		x 9 PC

Garden Trading®

Frilford 2 Seater Sofa Set Assembly Instructions

Please read through these instructions and ensure they are kept for future reference.
All parts and hardware are listed on the back of this guide.

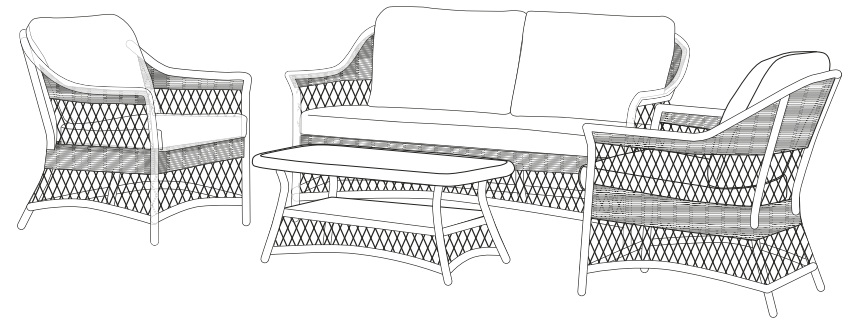

Settling in: A Guide To Your New Furniture

IMPORTANT

- For ease of assembly, we advise that two people work together, as parts can be heavy.
- Assemble your new furniture on a non-abrasive surface, such as a dust sheet or the original cardboard packaging.

1. PREPARATION

- Clear a large, flat area for assembly.
- Unbox all parts and check against the provided parts list.
- Keep small parts out of reach of children.

2. ASSEMBLY

- Ensure that all screws and fittings are loosely attached before tightening.
- We advise using only hand tools. Power tools can damage your new furniture.
- Avoid over-tightening screws, as this can lead to damage.
- Ensure the product is fully assembled before use.
- Leg Positioning: Make sure all legs are securely fitted and in full contact with the ground.

3. HANDLING

- To move your new furniture, always lift it. To avoid breakages, do not drag pieces across the floor.

4. CARE

- To maintain the condition of your furniture, avoid using abrasive or corrosive cleaning agents.
- We suggest using a garden furniture cover when your furniture is not in use to keep it clean and protected.

Garden Trading®

gardentrading.co.uk

customerservices@gardentrading.co.uk

TGTC, Hargreaves Road, Groundwell Industrial Estate, Swindon, SN25 5AZ

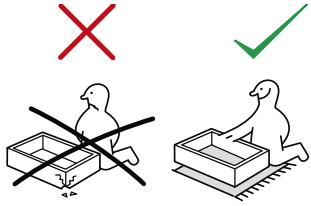

1

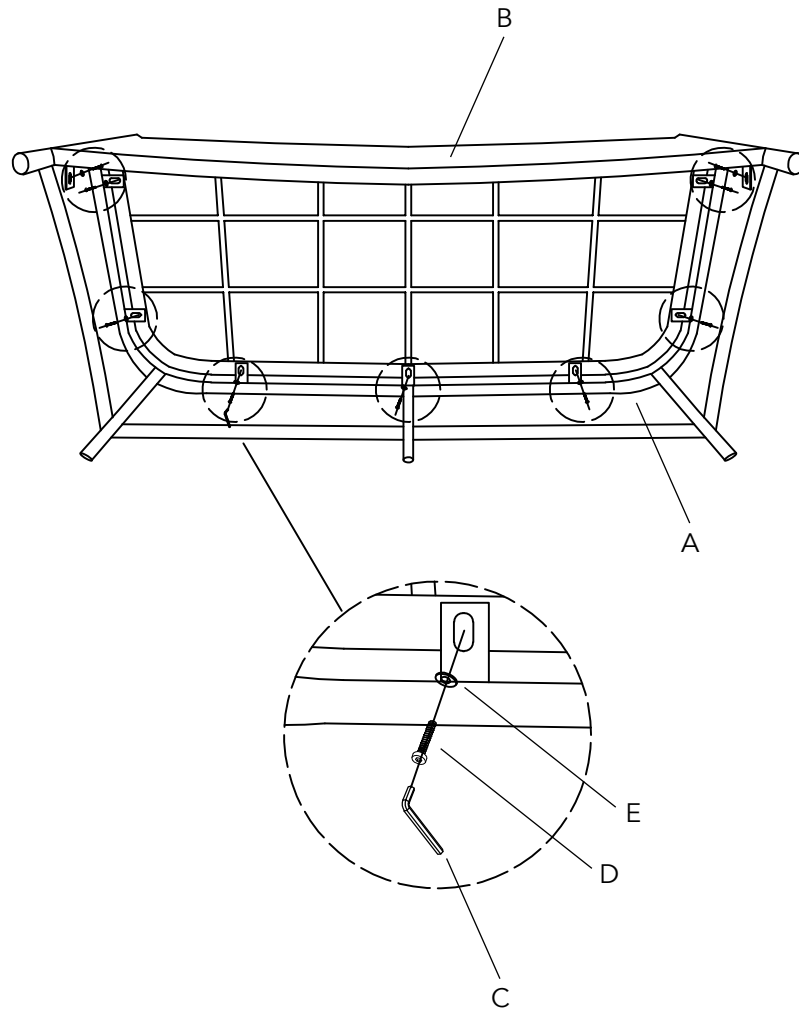

ASSEMBLY ADVICE

- Complete Before Use: Ensure the product is fully assembled before use.
- Child Safety: Keep small parts out of reach of children.
- Leg Positioning: Make sure all legs are securely fitted and in full contact with the ground.

CARE & MAINTENANCE:

- To ensure the longevity of your furniture, we recommend following the care Guidance outlined below:

FURNITURE CUSHIONS

- Storage: During extended periods of non-use or adverse weather conditions, store your furniture cushions in a dry and well-ventilated indoor space. Ensure all cushions are clean and completely dry before storage.
- Inspection: Regularly check cushions for signs of mould, mildew, or damage.
- Spillage Management: Address any spills immediately using an absorbent sponge or cloth to prevent staining.

TABLE TOPS

- Protective Measures: Always use coasters to shield table tops from heat and water marks.
- Careful Handling: When tilting the table, exercise caution to avoid loosening the glass surface.
- Immediate Cleanup: To prevent permanent stains, clean up any spills right away.
- Cleaning: We recommend using a glass or multi surface cleaner along with a soft sponge.

RATTAN & SYNTHETIC ROPE

- Debris Removal: Use a soft brush to remove leaves and garden debris. For dirty marks on the rattan, clean with a non-abrasive sponge and lukewarm, detergent-free soapy water, then rinse with fresh water and allow to dry.
- Protective Cover: We suggest using a garden furniture cover when your furniture is not in use to keep it clean and protected.

ALUMINIUM

- Cleaning: Clean the aluminium frame with a non-abrasive sponge and warm soapy water, then rinse with a hose.

By following this care Guidance, you can keep your furniture in prime condition for years to come. If you have any questions or require further assistance, please do not hesitate to contact us.